



PEGASUSTM

**Pegasus Rail System
Installation Manual**

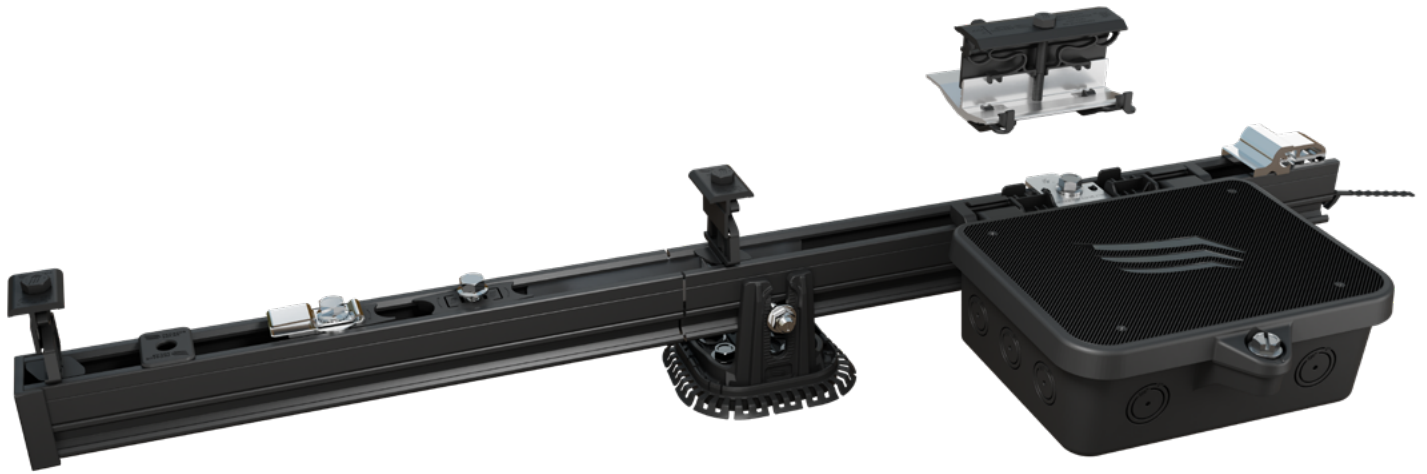

Table of Contents

- Overview.....3
- Disclaimer.....4
- Certifications & Code Compliances/ Product Identification.....5
- RequiredTools.....6
- Components and Installation Torque Requirements.....7
- Compatible Attachments.....8
- Compatible Mounts.....9
- Installation Process
 - T-Bolt / Splice Installation / Leveling the Rail11
 - MLPE Mount / Wire Management / Ground Lug.....12
 - Multi-Clamp / Hidden End Clamp.....13
 - Dual Rail - Setting PV Modules.....14
 - SkipRail.....15/16
 - N-S Bonding Jumper / Alternative Ground Lug / End Caps.....17
 - FX.....18/19
 - Tilt Leg Kit.....20
- Ground Path with N-S Bonding Jumper and Ground Lug.....21
- Ground Path with Ground Lugs only.....22
- Ground Path with SkipRail.....23
- Ground Path with FX.....24
- Ground Path with MLPE Integrated Grounding.....25
- Ground Path with Tilt Leg Kit.....26
- Appendix A - Compatible PV Modules.....27/28
- Appendix B - SkipRail Compatible PV Modules.....29
- Appendix C
 - Span Tables.....30
 - Warranty.....30
 - External Links.....30



Overview



The Pegasus Rail System is engineered to mechanically attach solar PV modules to residential and commercial sloped roofs. The system may be used to ground and bond solar PV modules complying with UL 2703 when the specific module has been evaluated for grounding and/or bonding in compliance with this manual. A list of evaluated modules is located in Appendix A. The installed mounting system and solar PV array should be inspected periodically for loose components, debris build-up (such as under the PV modules), and any corrosion. Any loose components, excessive debris, or corrosion should be remedied immediately by a licensed contractor.



Disclaimer

This manual describes proper installation procedures and provides necessary standards required for product reliability. All installers must thoroughly read this manual and have a clear understanding of the installation procedures prior to installation. Failure to follow these guidelines may result in solar array damage, property damage, bodily injury or even death. Warranty details are available at www.pegasussolar.com

THE INSTALLER IS RESPONSIBLE FOR:

- Ensuring all electrical components are installed by a licensed and bonded electrician or solar contractor.
- Ensuring all work complies with national, state and local installation laws and codes, and all work complies with all applicable local or national building and fire codes, including any that may supersede this document.
- Ensuring all information provided about the jobsite was accurately used in determining the compatibility of the system and the rail and mount spans.
- Ensuring all components are installed in accordance to this installation manual, and the spacing and use of mounts and rails are in compliance with Pegasus engineering span tables for the specific attributes of the solar array (e.g. wind load, building exposure, etc.).
- Using only Pegasus Solar components - substituting any components will void the Warranty unless explicated stated by Pegasus in writing.
- Providing an appropriate method of direct-to-earth grounding according to the latest edition of the National Electrical Code, including NEC 250: Grounding and Bonding, and NEC 690: Solar Photovoltaic Systems.
- Ensuring bare copper grounding wire does not contact aluminum components.
- Ensuring PV modules and module-level power electronics are installed in compliance with the respective manufacturers' installation manual and warranty terms and conditions.
- Not breaking the bonding path of the array during periodic maintenance.
- Upon maintenance of a Pegasus installed system, checking for loose components, excessive debris, and corrosion. The installer shall re-tighten any loose components immediately; remove any excess debris immediately, and replace any corroded components immediately.
- Ensuring all AC power is disconnected before servicing PV modules, wiring, and any module-level power electronics.
- Verifying that fasteners are clean and free of damage or signs of corrosion prior to installation



Certifications & Code Compliances/ Product Identification

Certifications and Code Compliance

BONDING AND GROUNDING

- Conforms to UL 2703, Ed. 1 Standard for Safety First Edition: Mounting Systems, Mounting Devices, Clamping/ Retention Devices, and Ground Lugs for Use with Flat-Plate Photovoltaic Modules and Panels.
- Certified to LTR AE-001-2012 Photovoltaic Module Racking Systems
- Max Overcurrent Protective Device (OCPD) Rating: 25A
- Max Module Size: 24ft²; Max Frameless Module Size for Canadian LTR-AE: 19.5 ft²
- Module Orientation: Portrait or Landscape
- System Level Allowable Design Load Rating: see PE stamped certification letters defining the actual system structural capacity (see Appendix B)
- Ground Lug conforms to UL 467

CLASS A SYSTEM FIRE RATING PER UL2703 & UL1703

- Any roof slope with Module Type 1, Type 2, Type 29, Type 30, Type 38
- Any module-to-roof gap; no deflectors required
- This rating is applicable with any third-party attachment
- Class A rated PV systems can be installed on Class A, B, and C roofs without affecting the roof fire rating



STRUCTURAL CERTIFICATION

- Designed and Certified for Compliance with the International Building Code, ASCE 7-10, ASCE 7-16, & ASCE 7-22
- For Dual Rail installations, up to 2 PV modules per pair of 7' of rails are allowed
- See PE Certified Span Tables in Appendix C for load ratings and details
- As specified in UL 61730-1 5.2.3DV, PV modules are considered to be in compliance with the mechanical loading and bonding and grounding requirements of UL 61730-1 when mounted, bonded and grounded in the manner specified by either the PV module mounting instructions, or the mounting system manufacturer's instructions when the mounting, bonding, and grounding means have been evaluated with the PV module to UL 2703.

WATER SEAL RATINGS: AC286

- Comp Mount has been tested and evaluated without sealant for roof slopes between 2:12 and 12:12

Product Identification

Product identification can be made by looking at the top of the Multi-Clamp:

- Model Name: "PRS"
- Lot Code: e.g. "A20-4"
- UL2703 listing: CSA Mark

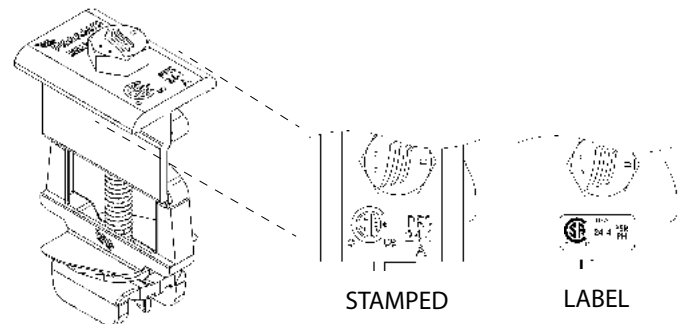

Required Tools



ROOFING CHALK



STRING LINE



MEASURING TAPE



1/2" DEEP SOCKET



TORQUE WRENCH



DRILL DRIVER



DRILL



JOBBER BIT



Components and Installation Torque Requirements

Rails and Splices

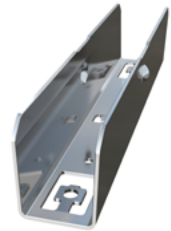
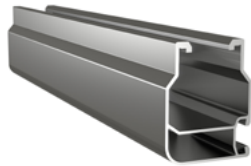
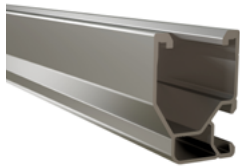

Pegasus Rail	Pegasus Max Rail	Splice	Max Splice
6' Spans up to 110 mph*	6' Spans up to 130 mph*	Structural, Non-interfering	Structural, Non-interfering
4' Spans up to 130 mph*	4' Spans up to 140 mph*	No Tools	No Tools
UL2703 Listed	UL2703 Listed	UL2703 Listed	UL2703 Listed

* Not for design use. See Appendix B - Span Tables for details.

Rails Components

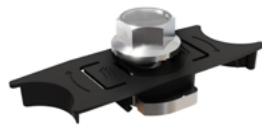

Multi-Clamp	Hidden End Clamp	MLPE Mount	Dovetail T-Bolt	Bond Box
Mid and End Clamp	Any PV module with frame flange	Compatible with most	For use with any mount or attachment	6 & 10 AWG Copper Wire
UL2703 Listed	UL2703 Listed	UL2703 Listed	UL2703 Listed	UL2703 and UL1741 Listed
1/2" Socket Torque: 100-130 in-lbs.	1/2" Socket Torque: 150-180 in-lbs.	1/2" Socket Torque: 150-180 in-lbs.	1/2" Socket Torque: 280-300 in-lbs.	1/2" Socket Torque: 150-180 in-lbs.

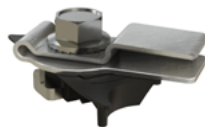

Wire Clip	Cable Grip	Ground Lug	N-S Bonding Jumper	End Cap & Max End Cap
Holds wire in Rail	Holds two trunk cables	6 & 8 AWG Copper Wire	Bonds PV modules	5 GPM drainage rate
UV stable and fire resistant	Holds four PV wires	UL2703 Listed	UL2703 Listed	UV stable and fire resistant
No tools	1/2" Socket Torque: 150-180 in-lbs.	1/2" Socket Torque: 150-180 in-lbs.	No tools	No tools



Components and Installation Torque Requirements

SkipRail Clamp



SkipRail Clamp	SkipRail Clamp w/ Kickstand
For SkipRail Installation method	For SkipRail Installation method
UL2703 Listed	UL2703 Listed
1/2" Socket Torque: 130-150 in-lbs.	1/2" Socket Torque: 130-150 in-lbs.

UL2703 Listed Roof Attachments



Intentionally Blank

Instaflash	Comp Mount
For Comp Shingle Roofs	For Comp Shingle Roofs
UL2703 Listed with Dovetail T-bolt	UL2703 Listed with Dovetail T-bolt



Tile Scissor Mount	Tilt-Leg Kit with L-foot	Tilt-Leg Kit for Instaflash
For Concrete Tile Roofs	For flat roof applications	For flat roof applications
UL2703 Listed with Dovetail T-bolt	UL2703 Listed with Dovetail T-bolt Torque: see install instructions	UL2703 Listed with Dovetail T-bolt Torque: see install instructions



Components and Installation Torque Requirements

UL2703 Listed Roof Attachments

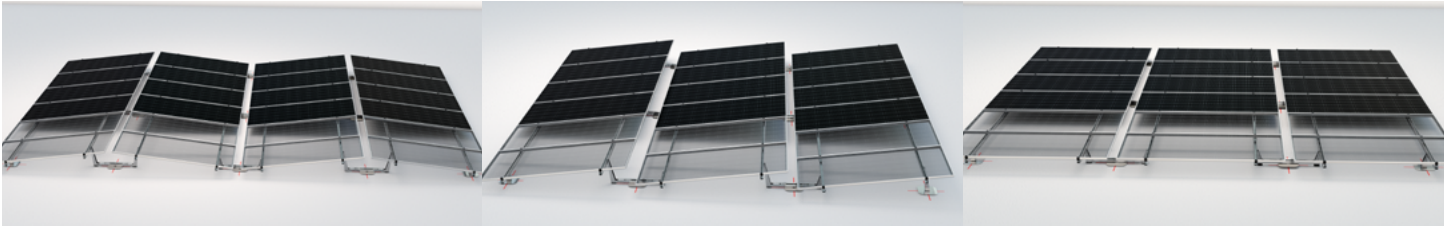

FX

For flat roof

UL2703 Listed with Dovetail T-bolt



Compatible Mounts

Comp Mounts



Comp Mount - Black

Comp Mount - Mill

For use on sloped asphalt or composite shingle roofs.

Tile Scissor Mounts

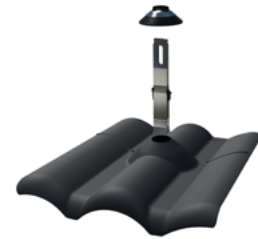
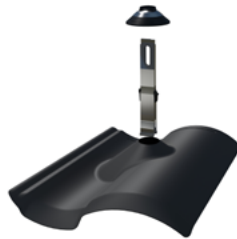
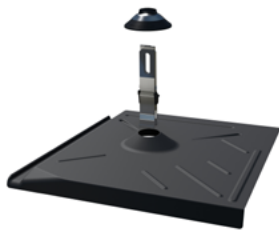

Flat Tile

S-Tile

W-Tile

For use on sloped concrete and clay tile roofs.

Third-Party Mounts and Attachments

When using a third party attachment or mount, refer to the manufacturer's installation manual. In all cases, the Dovetail T-bolt is required to attach the Rails to any third party attachment or mount. It is the installers responsibility to compare the load rating and span tables of the Pegasus Rail to the third party attachment ratings, and use the lesser of the two ratings when designing the system. For all third party mounts and attachments, when the Dovetail T-bolt and nut are installed and tightened to the attachment, the Dovetail T-bolt must be flush or extend past the last thread on the nut.



Installation Process

Rail and T-Bolt Installation



Place Dovetail T-Bolt in the slot of the L-Foot or other attachment. The Dovetail T-bolt is the only approved attachment bolt for the Rails for any mount or attachment.



- Insert the T-bolt into the rail slot and hand tighten
- Rail end must extend beyond attachment face for when using a splice



- Install additional rows of Rails spaced per PV module manufacturer's requirements
- Level Rail rows using a stringline
- Tighten the Dovetail T-bolt to 280-300 in-lbs. with a 1/2" socket

Splice Installation



Splice can be installed anywhere in a span, but must be used between two mounts (not in a cantilevered section of rail)



Insert the Splice into the first Rail up to the bump-stop (halfway). Push a second Rail on to the Splice up to the bump-stop.

Rail Cantilever



- For cantilevered ends of rail:
- Min. cantilever: 0.5in
 - Max. cantilever: 40% of attachment span

Thermal Break

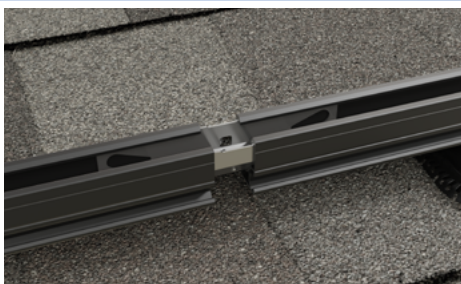

- Leave a 1" thermal break every 36ft of continuous Rails sections
- Thermal break must be offset 1" or more from attachment

Wire Management

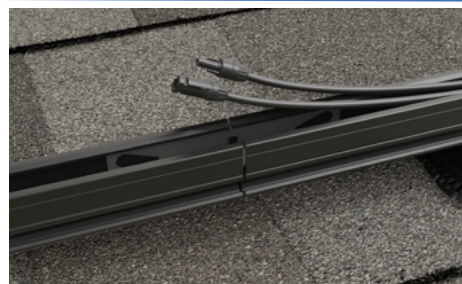

PV wires and MLPE trunk cables can be placed into the channel of the rail



The flanges of the Multi-Clamp will protect wires from the bolt after tightening*
*Partially protect for frames ≤ 32mm



Installation Process

MLPE Mount Installation

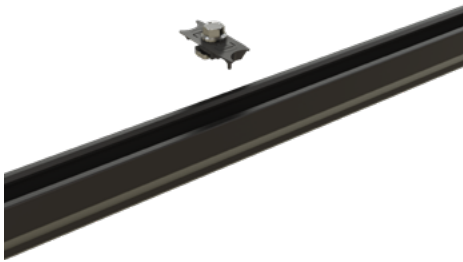

Position the MLPE Mount perpendicular to the rail opening, place on rail, and turn clockwise 90 degrees



Install the MLPE device to the MLPE Mount and tighten the bolt to 150-180 in-lbs with a 1/2" socket



Route wires before or after installing the MLPE

Cable Grip

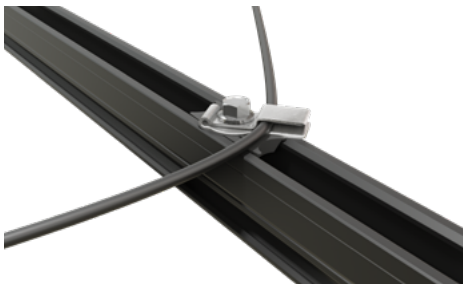

Like the MLPE Mount, twist-lock the Cable Grip into the open channel of the Rail



Cable Grip can be used to secure up to two trunk cables or four PV wires, and firmly secures and home-runs and

Wire Clip



Press firmly on top of Wire Clip lock into Rail. Use a screwdriver or similar tool through the hole to pry-out the Wire Clip if necessary.

Ground Lug Installation

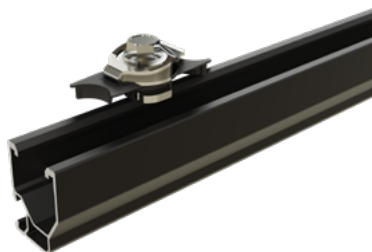

The Ground Lug comes preinstalled on a MLPE Mount. Determine best position for ground wire (e.g. near J-box); install the Ground Lug onto Rail.

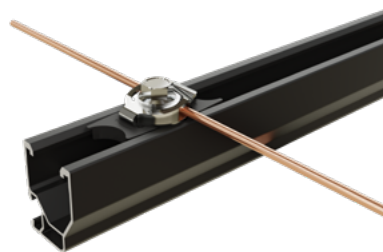

Run a 8 or 6 gauge copper ground wire from each Ground Lug to the J-box for connection to earth ground; tighten to 150-180 in-lbs with a 1/2" socket

Ground Lug w/ T-Bolt



Alternatively, remove the Ground Lug from the MLPE Mount and use a Dovetail T-bolt to attach the it to the Rail; tighten to 250-280 in-lbs with a 1/2" socket



Installation Process

Multi-Clamp Installation



Align the Multi-Clamp parallel with the rail, then insert into the rail channel



Push down and turn the Multi-Clamp clockwise 90 degrees

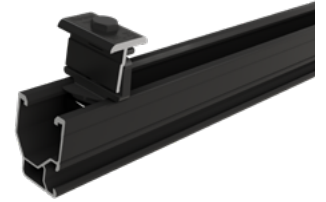

Multi-Clamp will click when it is engaged. Slide the Multi-Clamp up snug to the PV module frame



Multi-Clamp as mid-clamp
Any orientation acceptable



Multi-Clamp as end-clamp
Correct orientation

- Silver Bond Plate is hidden
- Arrow points to end panel



Multi-Clamp as end-clamp
Incorrect orientation

- Silver Bond Plate is visible
- Arrow points away from end panel

Hidden End Clamp Installation (optional)



After cutting the Rail to align with the edge of the to-be place PV module; slide the HEC into to the Rail opening, then place the PV module into position



Pull the tab until the HEC is fully engaged with the PV module frame, then hook the nearest Pulltab tooth onto the edge of the Rail



Tighten the HEC bolt with a 1/2" socket to 150-180 in-lbs. Then unhook the pull-tab and fold it into the Rail opening.



Installation Process

Dual Rail Installation - Setting PV Modules



Place the first PV module at the beginning of the row of Rails

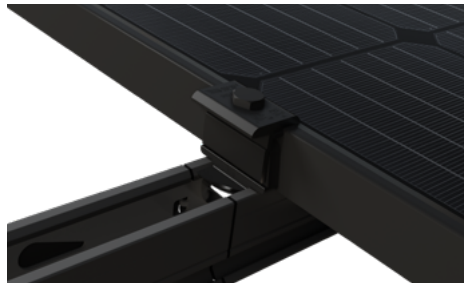

Install Multi-Clamp in Rail and slide flush against PV module. Tighten clamp with 1/2" socket to 100-130 in-lbs. Ensure Multi-Clamp is in the "End Clamp" orientation (see *Multi-Clamp Installation*).

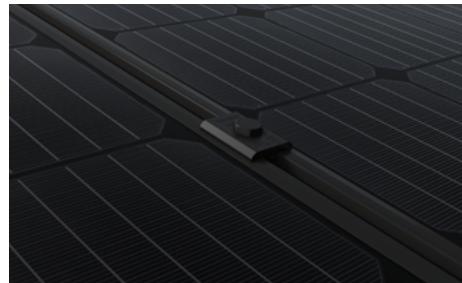

Install Multi-Clamp into Rail on the opposite side of the PV module. Place next PV module on rail and snug against Multi-Clamp, then tighten Multi-Clamp with 1/2" socket to 100-130 in-lbs.



Repeat the previous steps until the row is finished



Start the next row of panels. At least a 1/4" gap shall be between each row of PV modules.

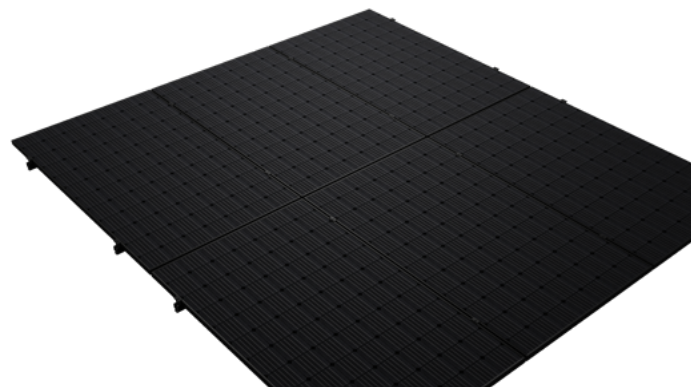
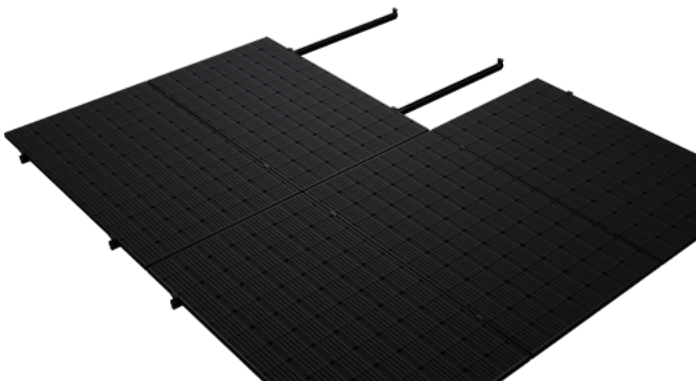

Continue the above steps for every row of modules until array is complete



Installation Process

SkipRail Installation

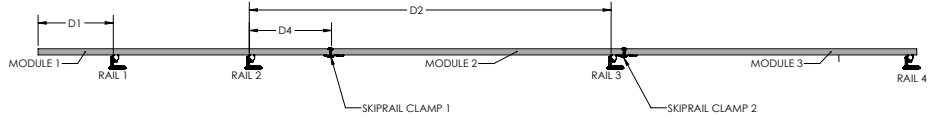

Mark the array layout. For the first installed row or partial row of PV modules, install Rail 1 and Rail 2 in the typical method, spacing the rails per the PV module manufacturer's mounting location instructions.

For Rails 3 and higher, space the Rails so $D2 =$ up-roof length of the module 5 inches. For example, for a PV module in portrait that is 68" long, space the 3rd, 4th, 5th, etc. Rail at $D2 = 63"$ to $73"$ from the previous Rail. For a PV module in landscape that is 40" wide, space the 3rd, 4th, 5th, etc. Rail at $D2 = 35"$ to $45"$ from the previous Rail. There shall always be at least one Rail supporting each PV module.

In all cases, $D3 > 3"$, where $D3$ is the distance from the outer edge of the PV module frame to center of the Rail.

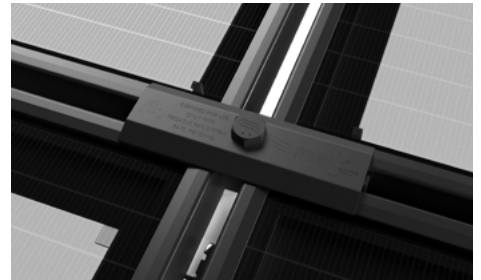
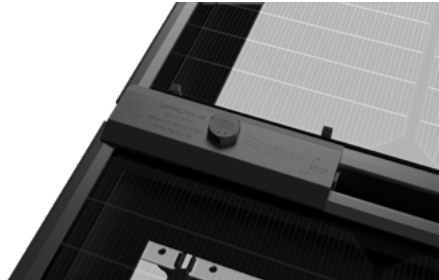

Install the first row of PV modules as normal, ensuring the PV module cantilever distance $D1$ meets the PV module manufacturers requirements.

At the end of each row of PV modules, or where a gap between PV modules exists:

Portrait Panels: install a SkipRail Clamp 0.0" to 0.5" from the edge of the panel.

Landscape Panels: install SkipRail Clamp 0.0" up to 25% of the long side of the panel from the edge of the panel

Tighten the SkipRail Clamp bolt to 130-150 in-lbs. with a 1/2" socket.

Within the above-row of PV modules, install a SkipRail Clamp centered across where the to-be-installed above row of PV modules will be placed.

Tighten the SkipRail Clamp bolt to 130-150 in-lbs. with a 1/2" socket.

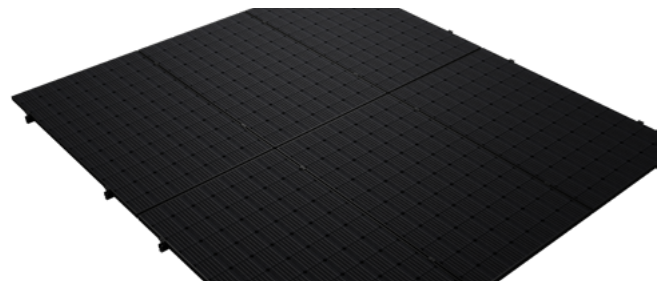
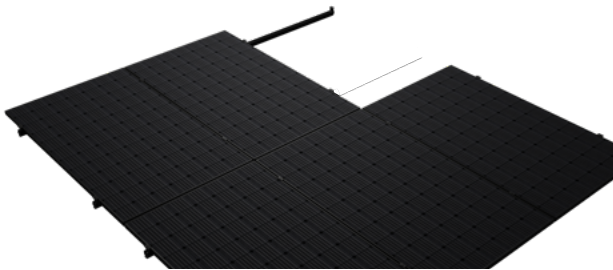

Install the next row of PV modules into the open side of the Skip Rail Clamp, then lower onto the Rail. Tighten Multi-Clamps as previously described.

Finish installing all PV modules



Installation Process

SkipRail Installation

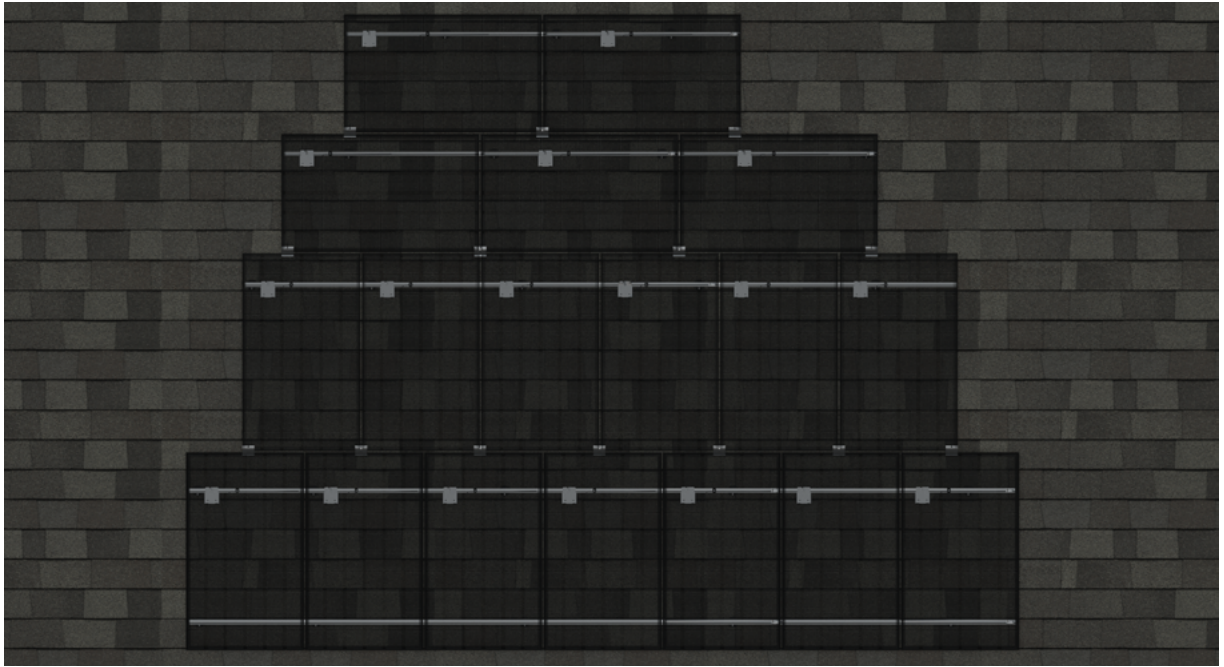

Example mixed orientation array on a Comp Shingle roof. Any set of panels that are the first row in their column shall be installed using the standard Dual Rail method as shown on the right hand side of this array.

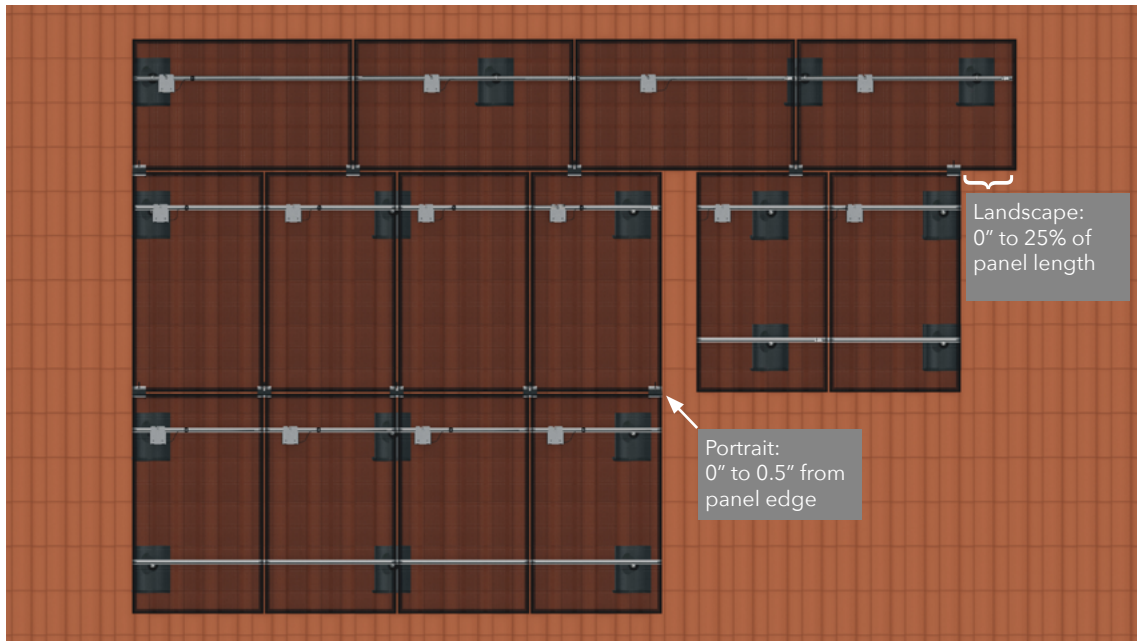

Example mixed orientation array with pipe-vent clearance on a Tile roof. Any set of panels that are the first row in their column shall be installed using the standard Dual Rail method as shown on the right hand side of this array.



Installation Process

N-S Bonding Jumper Installation (optional)

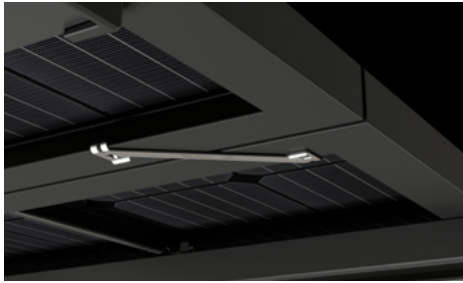

Attach Bonding Jumpers on the underside of PV modules in adjacent rows



From under the PV module, align the Jumper with the frame lip of each PV module

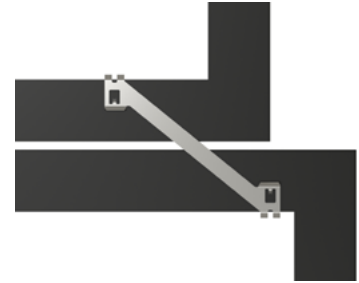

Firmly press each side of the Jumper onto each PV module frame until fully seated

End Cap Installation (optional)

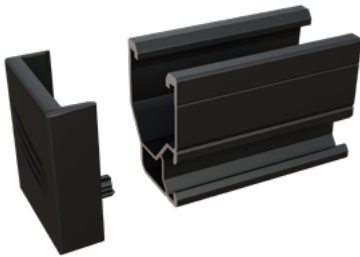

Line the tabs on the end cap up with the hollow part of the rail



Press firmly until the End Cap is fully seated against the Rail

Alternative Ground Lug (optional)

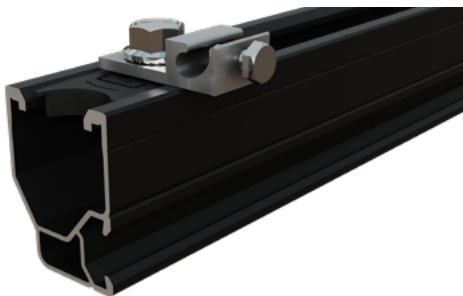

A WEEB-LUG-8.0 or equivalent can be installed onto the MLPE Mount in the Rail; tighten MLPE bolt with a 1/2" socket to 150-180 in-lbs. Install ground wire and tighten lug bolt to 84 in-lbs.

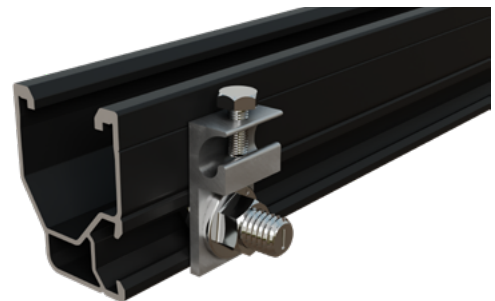

A WEEB-LUG-8.0 or equivalent can be installed onto the Dovetail T-bolt; tighten the T-bolt with a 1/2" socket to 250-280 in-lbs. Install ground wire and tighten lug bolt to 84 in-lbs.



Installation Process

FX System

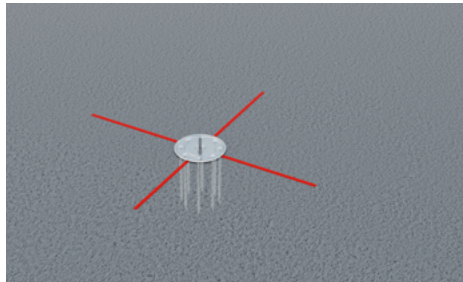

1
Mark array and anchor location. Install anchors per manufacturer specs. Use Glide software to determine anchor location.



2
Install EPDM pad onto spanner bracket.

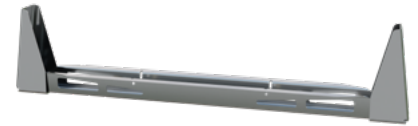
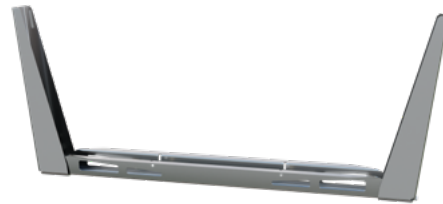
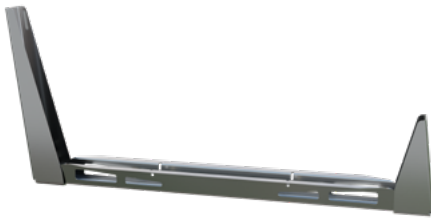

3A - South

Install legs onto spanner bracket.
Torque to 150-180 in-lbs.

3B - East-West

3C - Flush

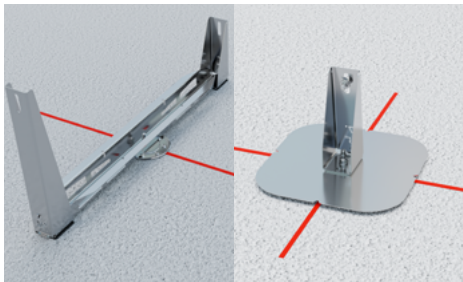

4
Mount dual leg assembly or single leg onto roof anchor. Torque to manufacturer spec.

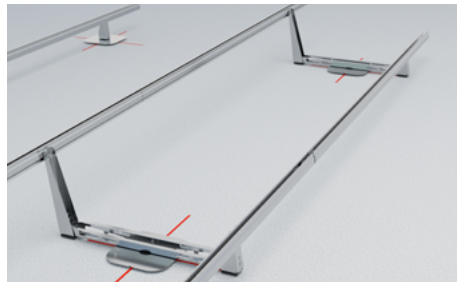

5
Install Pegasus Max Rail onto legs with Dovetail T-bolt. Torque to 280-300 in-lbs.



Installation Process

FX System



6

Install MLPE using Pegasus MLPE mount. Torque to 150-180 in-lbs. Use rail channel as wire raceway.

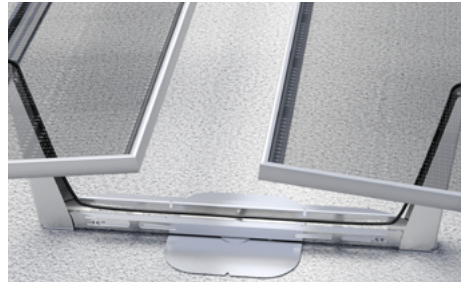

7

Route homerun wires through spanner bracket.

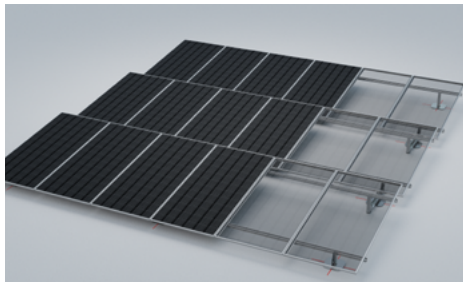

8A - South

Install PV modules using the Pegasus Multi-Clamp or Hidden End Clamp (see page 12 & 13). Ensure PV module cantilever meets module manufacturer requirements.



8B - East-West



8C - Flush



Installation Process

Tilt Leg Kit

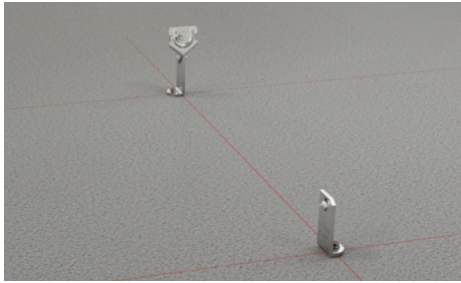

1

Mark array and feet location and install lower legs and upper legs for desired spacing and tilt angle

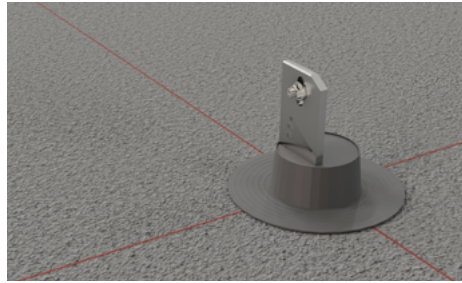

2

Flash each L-foot with 3rd party flashing system

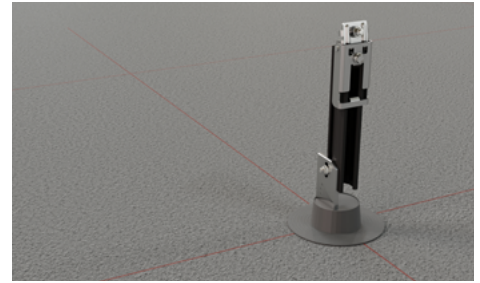

3

Using Pegasus Rail or Pegasus Max Rail, cut leg sections to desired length, and install onto Upper Leg L-foot and Upper Leg Bracket. Torque to 250in-lbs

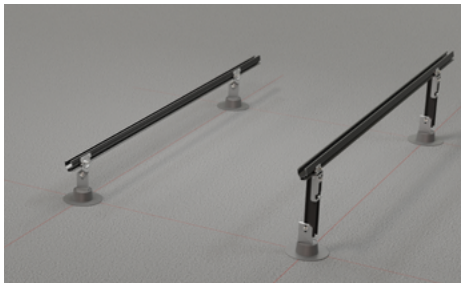

4

Multi-Clamp as mid-clamp
Any orientation acceptable



5

Install MLPE and manage wires in the Pegasus Rail channel

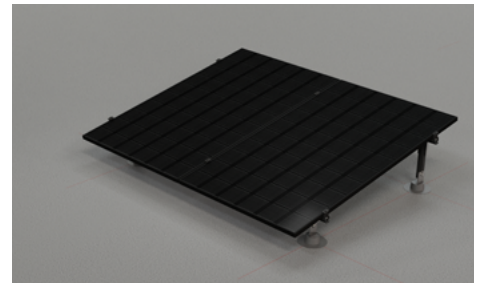

6

Install PV Modules using the Pegasus Rail System components



Pegasus Rail System - Bond Path to Ground

Ground Lug & N-S Bonding Jumper

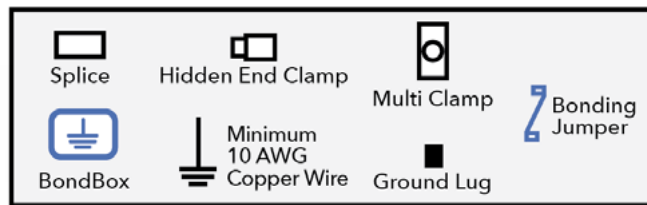
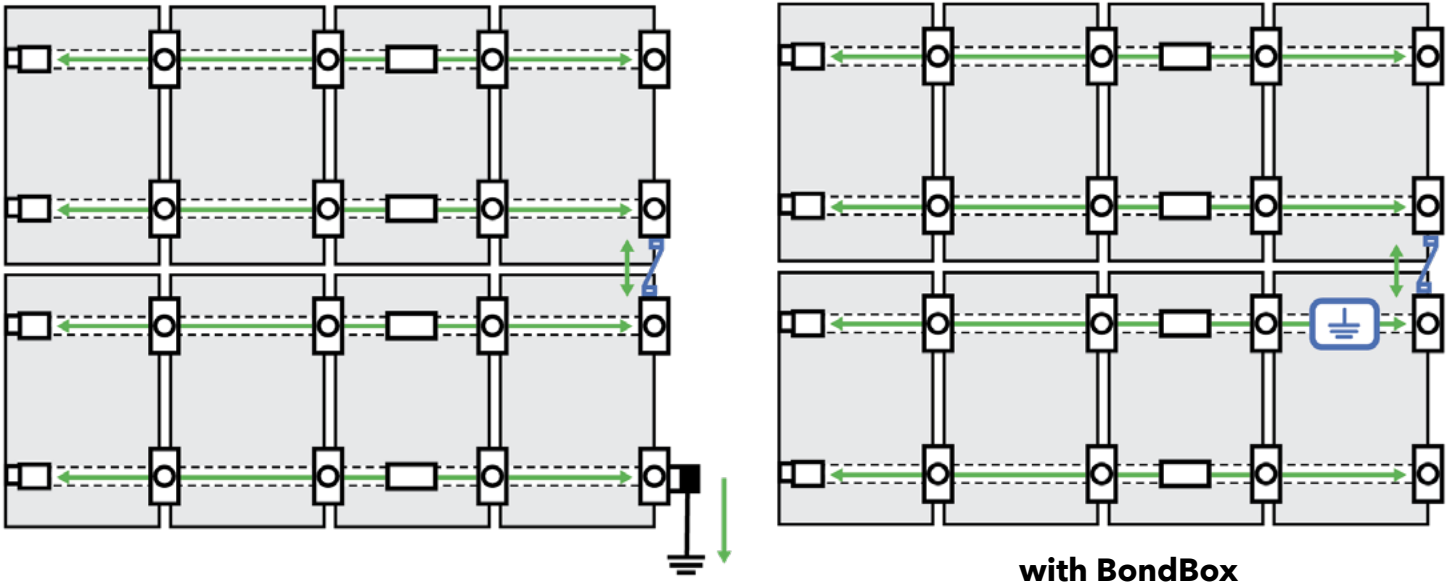

Multi-Clamps bond adjacent PV modules to one another and to the Rail. The Splice provides a bond connection between two Rail sections, including when a 1" thermal gap is utilized. The N-S Bonding Jumper will provide a bonding path between rows of PV modules, so that one Ground Lug per array is necessary for earth ground. If a thermal break is left between two sections or Rail, the Multi-Clamps will provide a bond path across the two Rails through the PV module frame.

The N-S Bonding Jumper may only be used with the Pegasus Rail System, and is not certified for use with any other mounting system.

If the N-S Bonding Jumper needs to be removed during maintenance, a second N-S Bonding Jumper shall first be placed on the other side of the array.



Pegasus Rail System - Bond Path to Ground

Ground Lug for each PV Module Row

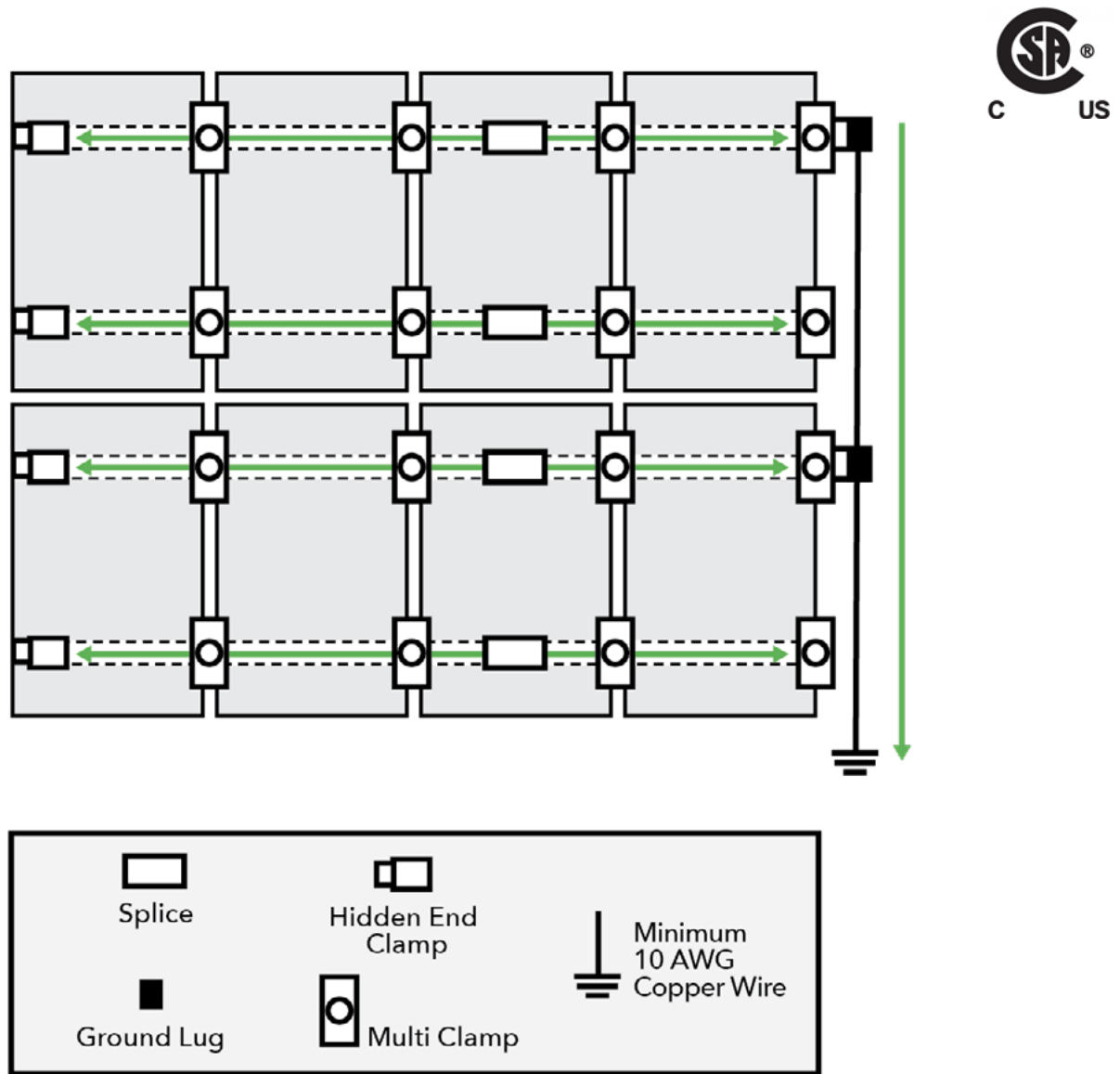

Multi-Clamps bond adjacent PV modules to one another and to the Rail. The Splice provides a bond connection between two Rail sections, including when a 1" thermal gap is utilized. One Ground Lug is required per row of PV Modules, with a final earth ground connection at the terminal end of the ground wire. If a thermal break is left between two sections or Rail, the Multi-Clamps will provide a bond path across the two Rails through the PV module frame.



Pegasus Rail System - Bond Path to Ground

SkipRail System

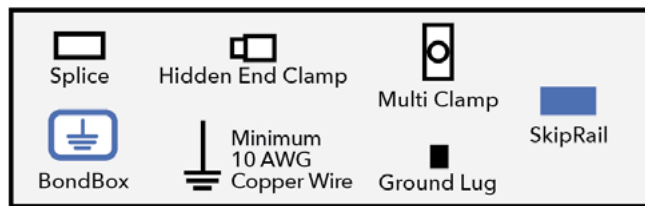
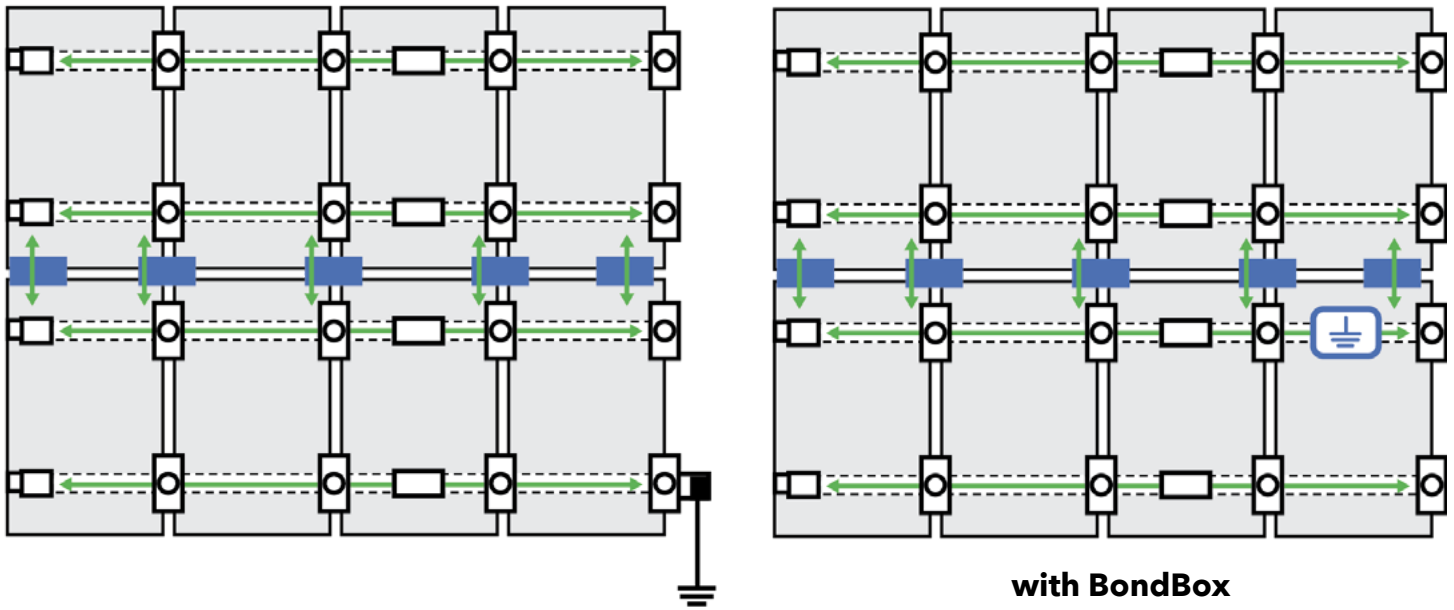

Multi-Clamps bond adjacent PV modules to one another and to the Rail. The Splice provides a bond connection between two Rail sections, including when a 1" thermal gap is utilized. The SkipRail Splices will provide a bonding path between rows of PV modules, so that one Ground Lug per array is necessary for earth ground. If a thermal break is left between two sections or Rail, the Multi-Clamps will provide a bond path across the two Rails through the PV module frame.



Pegasus Rail System - Bond Path to Ground

FX System

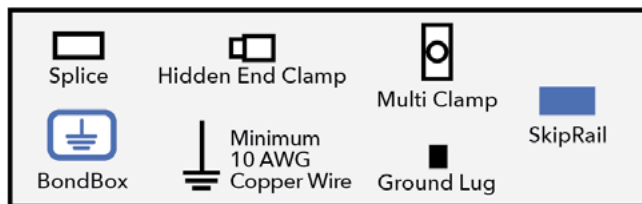
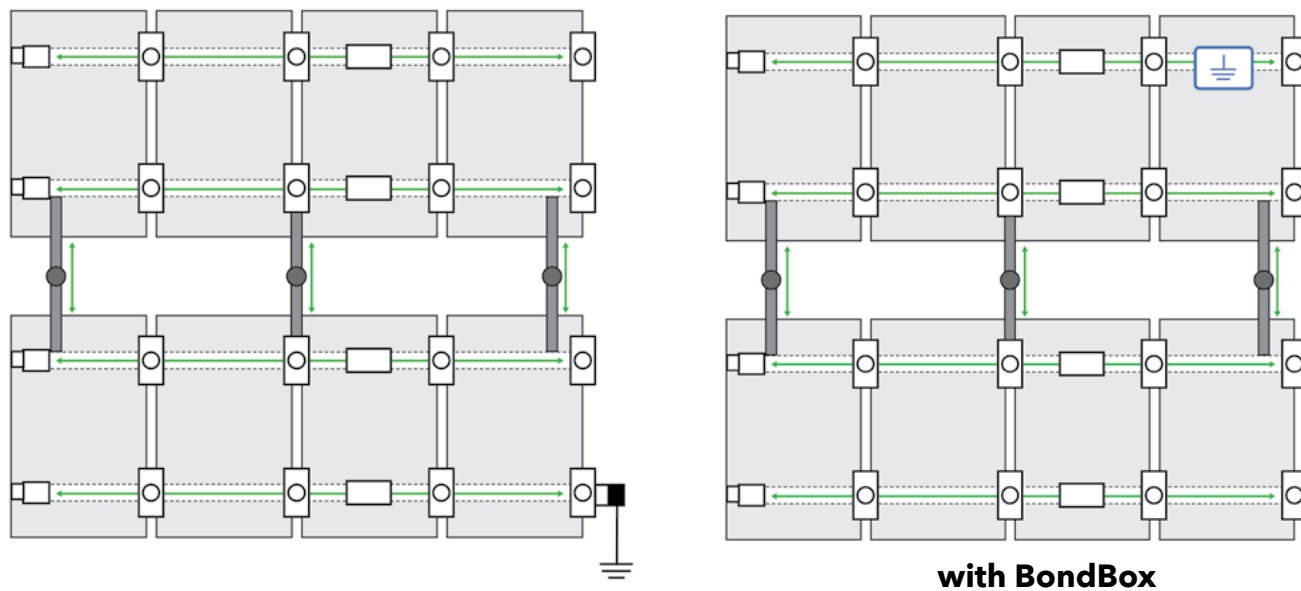

Multi-Clamps bond adjacent PV modules to one another and to the Rail. The Splice provides a bond connection between two Rail sections, including when a 1" thermal gap is utilized, or if a thermal break is under a PV module the Multi-Clamps will additionally provide a bond path across the two Rails through the PV module frame. The dual leg assembly provides a bonding path between adjacent columns of PV modules.



Pegasus Rail System - Bond Path to Ground

Using Enphase Products

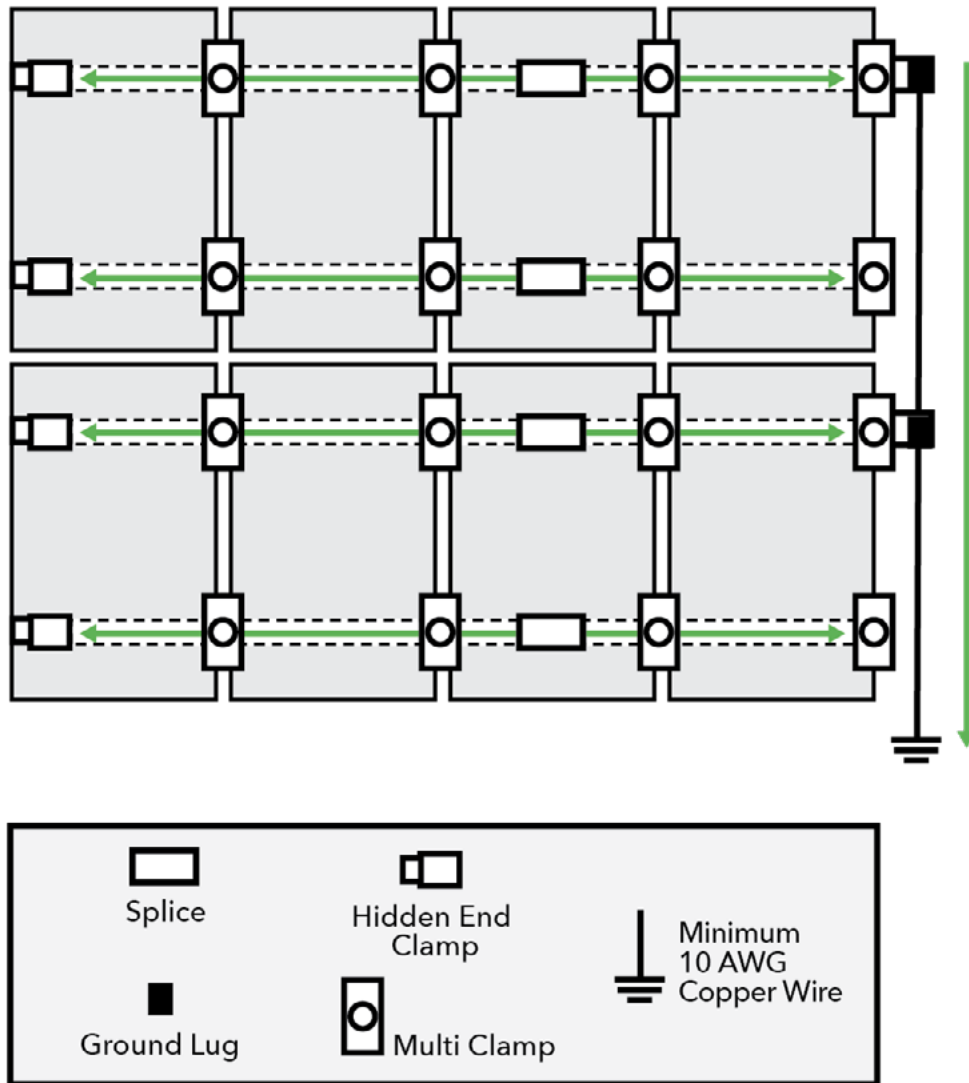

Multi-Clamps bond adjacent PV modules to one another and to the Rail. The Splice provides a bond connection between two Rail sections, including when a 1" thermal gap is utilized. The MLPE Mount creates a bond connection to the MLPE. When using Enphase products, Ground Lug, N-S Bonding Jumpers, or other equipment ground conductors (EGC) are not required, and the use of the En phase products satisfies the UL2703 bonding and grounding requirements.

Compatible Enphase products:

- Microinverters M250-72, M250-60, M215-60, C250-72; with Engage cables ETXX-240, ETXX-208, ETXX-277



Pegasus Rail System - Bond Path to Ground

Tilt Leg Kit

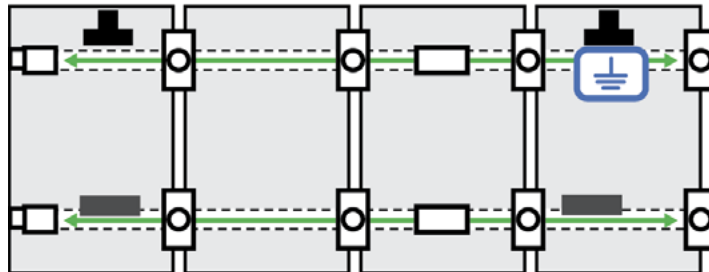
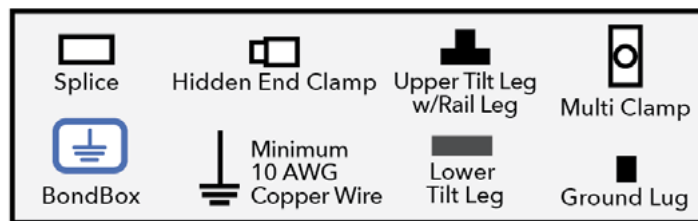
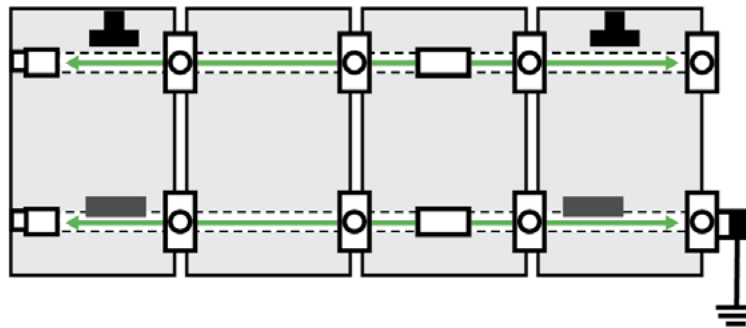

with BondBox

Multi-Clamps bond adjacent PV modules to one another and to the Rail. The Splice provides a bond connection between two Rail sections, including when a 1" thermal gap is utilized. One Ground Lug is required per row of PV Modules, with a final earth ground connection at the terminal end of the ground wire. If a thermal break is left between two sections or Rail, the Multi-Clamps will provide a bond path across the two Rails through the PV module frame.

Lower Tilt Leg Bracket bonds to the lower Rail. Upper Tilt Leg Bracket bonds the upper Rail to the Tilt Leg.



Appendix A - Compatible PV Modules

REV 33

Pegasus Rail System may be used to ground a PV module complying with UL 2703 only when the specific module has been evaluated for grounding and/or mounting in compliance with this installation manual. Unless otherwise specified, "xxx" refers to the power rating of the PV module. Both black & silver frames are included in the UL2703 listing.



Manufacturer	Model
Alexus Solar	ALEX-XXX-W-72-S; ALEX-XXX-B-54-S
Auxin	AXN6M612Txxx
Aptos	DNA-144-BF26-xxxW; DNA-144-MF26-xxxW; DNA-120-BF26-xxxW; DNA-120-MF26-xxxW; DNA-120-MF10-xxxW; DNA-120-BF10-xxxW; DNA-108-BF10-xxxW; DNA-108-MF10-xxxW; DNA-120MF23-xxxW
Axitec	AC-xxxM/156-60S; AC-xxxM/60S; AC-xxxMH/120S; AC-xxxMH/144S; AC-xxxMBT/108V; AC-xxxTGBl/108WB
Boviet	BVM6610M-xxx; BVM6610P-xxx
Canadian Solar	CS1H-xxxMS; CS1K-xxxMS; CS1Y-xxxMS; CS3K-xxxMS; CS3U-xxxMS; CS6K-xxxM; CS6K-xxxMS; CS6K-xxxP; CS6U-xxxM; CS6U-xxxP; CS6X-xxxM; CS6X-xxxP; BiHiKu CS3W-xxxMB-AG; CS3L-xxxMS; CS6R-xxxMS; CS3W-xxxPB-AG; CS3W-xxxP; CS3W-xxxMS; CS3L-xxxP; CS3L-xxxMS; CS3N-xxxMS; CS6W-xxxMB-AG; CS7N-xxxMB-AG; CS6.1-54TM-xxxH; CS6.1-60TM-xxxH; CS6.2-48TM-xxxH
CertainTeed	CTxxxHC11-04; CTxxxM10-02; CTxxxM11-02; CTxxxM11-03; CTxxxHC00-04; CTxxxHC12-06; CTxxxHC11-06; CTM10440HC11-09
Chint Solar	CHSM6612M-xxx
Freedom Forever	FF-MP-BBB-xxx
Gstar	GSD7S54T-xxxBT
Hansol	HSxxxTD-AN3
Heliene	Heliene20M xxx; Heliene36M xxx; Heliene36P xxx; Heliene60M xxx; Heliene60P xxx; Heliene72M Bifacial xxx; Heliene72P xxx; Heliene96M xxx Bifacial; Heliene96M xxx; Heliene 96P xxx; HSPE-144M M6 HC Bifacial xxx; HSPE 120M M6 HC Monofacial xxx; 144HC-M10-Bifacial; 460-144M-HC-M6; 156HC M10 NTYP SL Bifacial
Hyperion	HY-DH108P8B-xxx
Hyundai	HiD-SxxxRG(BK); HiS-MxxxRG; HiS-SxxxKI; HiS-SxxxRG; HiS-SxxxRG(BK); HiS-SxxxRI; HiS-SxxxTI; HiA-SxxxHI; HiS-SxxxXG(BK); HiN-SxxxXG(BK); HiS-SxxxYH(BK); HiN-TxxxNF(BK); HiS-TxxxNF(BK)
Imperial Star	ISM7-SHDD108-xxx/M; ISM7-SHSB108-xxx/M
JA Solar	JAM72S01-xxx/PR; JAP72S01-xxx/SC; JAM72D20-xxx/MB; JAM54S30-xxx/LR; JAM72D30-xxx-MB-DS; JAM54S31-xxx-MR; JAM54D41-xxx/MB; JAM54S30-xxx/MR; JAM66D45-xxx/LB
Jinko	JKMxxxM-60; JKMxxxM-60B; JKMxxxM-60BL; JKMxxxM-60HBL; JKMxxxM-60L; JKMxxxM-60L; JKMxxxM-60V; JKMxxxM-72; JKMxxxM-72HL-V; JKMxxxM-72H-V; JKMxxxM-72-V; JKMxxxP-60; JKMxxxPP-60; JKMxxxN-6RL3; JKMxxxM-6RL3-B; JKMxxxM-7RL3-TV; JKMxxxM-72HBL-V; JKMxxxN-54HL4-B
LG	LGN1K-G4; LGS1C-A5; LGxxxA1C-A5; LGxxxE1C-A5; LGxxxE1K-A5; LGxxxN1C-A3; LGxxxN1C-A5; LGxxxN1C-B3; LGxxxN1C-G3; LGxxxN1C-G4; LGxxxN1C-V5; LGxxxN1C-Z4; LGxxxN1K-A5; LGxxxN1K-G4; LGxxxN1K-V5; LGxxxN1K-Z4; LGxxxN2T-A5; LGxxxN2W-A5; LGxxxN2W-G4; LGxxxN2W-V5; LGxxxN2W-L5; LGxxxO1CA5; LGxxxQ1C-V5; LGxxxQ1K-A5; LGxxxQ1K-V5; LGxxxS1C-A5; LGxxxS2W-A5; LGxxxS2W-A5; LGxxxN1K-L5; LGxxxNIC-N5; LGxxxM1K-A6; LGxxxN1K-B6; LGxxxQ1C-A6; LGxxxQAC-A6; LGxxxQAK-A6; LGxxxM1C-A6; LGxxxN2W-E6; LGxxxN2T-E6; LGxxxN1K-E6; LGxxxN3K-V6; LGxxxN1C-A6
Longi	LR6-60BP-xxx; LR6-60HPB-xxx; LR6-60HPH-xxx; LR6-60PB-xxx; LR6-60PE-xxx; LR6-60-xxx; LR4-60HPH-xxxM; LR4-HPB-xxxM; LR4-72HPH-xxxM; LR4-72HBD-xxxM; LR5-54HPH-xxxM; LR5-72HBD-xxxM; LR5-54HABB-xxxM; LR5-54HPB-xxxM; LR7-72HGD-xxxM; LR8-54HGGB-xxxM; LR5-54HIB-xxxM; LR8-54HGGB-xxxM
Maxeon	SPR-MAX3-xxx-COM; SPR-MAX3-xxx-BLK; SPR-MAX5-xxx-COM; SPR-MAX6-xxx-COM; SPR-X21/22-xxx-COM; SPR-MAX3-XXX-BLK-R; SPR-MAX6-XXX-BLK
Meyer Burger	MB_B120AyB-xxx; MB_TG120ByB-xxx; MB_W120AyB-xxx
Mission Solar	MSE60Axxx; MSExxxSB1A; MSExxxSO6J; MSExxxSQ5K; MSExxxSQ5T; MSExxxSQ8K; MSExxxSQ8T; MSExxxSQ9S; MSExxxSX6S; MSExxxSX6W; MSExxxSX5T; MSExxxSX5K; MSExxxSX5R; MSExxxSX6Z; MSExxxSX9R; MSExxxSX9Z; MSExxxSR9S; MSExxxSR8K; MSExxxSR8T; MSExxxHTOB; MSI10-xxxHT4G; MSI10-xxxHT4T; MSI10-xxxHN4G; MSExxxHN0B; MSX10-xxxHN0B
Mitrex	Mxxx-L3H; Mxxx-I3H; Mxxx-H1H; Mxxx-B1F; Mxxx-A1F
mSolar	TXI10-xxx108BB
Panasonic	VBHNxxxKA01; VBHNxxxKA03; VBHNxxxSA16; VBHNxxxSA16B; VBHNxxxSA17; VBHNxxxSA17E; EVPVxxx; EVPVxxxK; EVPVxxxPK; EVPVxxxH; EVPVxxxHK; EVPVxxxPK
Philadelphia Solar	PS-M60(BF)-xxx; PS-M72(BF)-xxx; PS-MNB144(HCBF)-xxxW; PS-MNB108(HCBF)-xxxW
Phono Solar	PSxxxM6-18/VHB; PSxxxM6H-18/VHB; PSxxxM8GFH-18/VNHB; PSxxxM8GFH-18/VNH; PSxxxL8GFH-16/QNH



Appendix A - Compatible PV Modules (cont.)

Pegasus Rail System may be used to ground a PV module complying with UL 2703 only when the specific module has been evaluated for grounding and/or mounting in compliance with this installation manual. Unless otherwise specified, "xxx" refers to the power rating of the PV module. Both black & silver frames are included in the UL2703 listing.



Manufacturer	Model
QCells	Q.Peak 265; Q.PEAK BLK-G3.1 xxx; Q.PEAK BLK-G4.1 xxx; Q.PEAK DUO BLK-G5 xxx; Q.PEAK DUO BLK-G5/SC xxx; Q.PEAK DUO BLK-G6+ xxx; Q.PEAK DUO G6+ xxx AC ENP 1Q7+; Q.PEAK DUO BLK G9+ xxx; Q.PEAK DUO L-G5.2 xxx; Q.PEAK DUO L-G5.3 xxx; Q.PEAK Duo-G5 xxx; Q.PEAK DUO-G5/SC xxx; Q.PEAK DUO-G7 xxx; Q.PEAK G4.1 xxx; Q.PEAK G4.1/ Max xxx; Q.PEAK G4.1/SC xxx; Q.PEAK G4.1/TAA xxx; Q.PEAK L-G4.2 xxx; Q.PLUS BFR G4.1 xxx; Q.PLUS BFR-G4.1/TAA xxx; Q.PLUS L-G4.1 xxx; Q.PLUS L-G4.2 xxx; Q.PLUS L-G4.2/TAA xxx; Q.PRO BFR-G4.1 xxx; Q.PEAK DUO L-G8.2 xxx; Q.PEAK DUO BLK-G8 xxx; Q.PEAK DUO BLK-G8+ xxx; Q.PEAK DUO BLK ML G9 xxx; Q.PEAK DUO BLK ML G9+ xxx; Q.PEAK DUO BLK-G10 xxx; Q.PEAK DUO BLK-G10+ xxx; Q.PEAK DUO ML-G10+; Q.PEAK DUO BLK ML-G10.a+; Q.PEAK Duo XL G10 xxxBFG; Q.PEAK DUO-G10 xxx; Q.PEAK DUO-G10+ xxx; Q.PEAK DUO-G10.a xxx; Q.PEAK DUO-G10.a+ xxx; Q.PEAK DUO BLK -G10.a xxx; Q.PEAK DUO BLK-G10.a+ xxx; Q.PEAK DUO ML-G10 xxx; Q.PEAK DUO ML-G10.a xxx; Q.PEAK DUO ML-G10.a+ xxx; Q.PEAK DUO BLK ML-G10 xxx; Q.PEAK DUO BLK ML-G10+ xxx; Q.PEAK DUO BLK ML-G10.a xxx; Q.PEAK Duo ML-G10+ /t xxx; Q.TRON BLK M-G2+ xxx; Q.TRON M-G2+ xxx; Q.TRON XL-G2.3/ BFG; Q.PEAK DUO XL-G11S.3/BFG; Q.PEAK DUO XL-G11.3/BFG; Q.PEAK DUO XL-G11.3; Q.PEAK DUO ML-G12S.3 / BFG; Q.PEAK DUO ML-G12S.d / BFG; Q.TRON BLK M-G2+/AC; Q.PEAK DUO BLK ML-G10.a+; Q.PEAK DUO BLK ML-G10+; Q.PEAK DUO BLK ML-G10.B+; Q.PEAK DUO BLK ML-G10.C+; Q.TRON BLK M-G2.H+; Q.TRON BLK M-G2.H1+/AC; Q.TRON BLK M-G2+; Q.TRON BLK M-G2.F+; Q.TRON BLK M-G2+/AC; Q.TRON BLK M-G2.H1+/AC; Q.TRON BLK M-G2.F1+/AC
REC	RECxxxNP; RECxxxNP Black; RECxxxPE; RECxxxPE 72; RECxxxPE(BLK); RECxxxTP; RECxxxTP BLK; RECxxxTP2; RECxxxTP2 BLK; RECxxxTP2 BLK Q2; RECxxxTP2 BLK2; RECxxxTP2M; RECxxxTP2S 72; RECxxxAA; RECxxxAA Pure; RECxxxAA Black; RECxxxAA 72; RECxxxAA PURE-R; RECxxxNP3 Black; RECxxxNP2 Black; RECxxxNP2; RECxxxAA Pure-RX; RECxxxAA Pure 2; RECxxxAA PRO L; RECxxxAA Pro M
S-Energy	SNxxxM-10; SNxxxM-10(B); SNxxxM-10T; SC20-60MBE-xxxM
SEG	SEG-xxx-BMA-HV; SEG-xxx-BMA-TB; SEG-xxx-BMA-BG; SEG-xxx-BMB-HV; SEG-xxx-BMA-BG; SEG-xxx-BMD-HV; SEG-xxx-BMD-TB; SEG-xxx-BMB-BG; SEG-xxx-BMC-HV; SEG-xxx-BMC-TB; SEG-xxx-BMC-BG; SEG-xxx-BTD-BG; SEG-xxx-BTB-BG
Seraphim	SRP-xxx-BMD-HV;
Silfab	SILxxxBL; SILxxxNL; SLAxxxM; SLAxxxM; SLGxxxM; SSAxxxM; SIL-xxxNX; SIL-xxxHL; SIL-xxxNX; SIL-xxxBK; SIL-xxxHC; SIL-xxxHC+; SIL-xxxBG; SIL-xxxHN; SIL-xxxHM; SIL-520QM; SIL-xxx-QD; SIL-xxx XM
Sirius	ELNSM54M-HC-xxxW
Sonali	SS-xxxW-M60 M10
Solar4America	S4Axxx-72MH5BB; S4Axxx-60MH5BB; S4Axxx-108MH10BB; S4Axxx-144MH10STT; S4Axxx-108TH10BB; S4Axxx-144TH10STT; S4Axxx-108TH16BB; S4Axxx-144TH16XXX
SolarEver	SE-182*91-xxxM-108N; SE-166*83-xxxM-144; SE-182*91-XXXM-108; SE-182*91-XXXM-144; SE-182*105-xxxM-96-BD
Solaria	PowerXT-xxxR-AC; PowerXT-xxxR-BD; PowerXT-xxxR-BX; PowerXT-xxxR-PD; PowerXT-xxxR-PX; PowerXT-xxxR-PM; PowerXT-xxxR-PL; PowerX-xxxR; PowerX-xxxR-4T
SunPower	SPR-Axxx-G-AC; SPR-E19-xxx; SPR-E19-xxx-D-AC; SPR-E20-xxx; SPR-E20-xxx-C-AC; SPR-E20-xxx-COM; SPR-E20-xxx-D-AC; SPR-E20-xxx-E-AC; SPR-X20-xxx-D-AC; SPR-X20-xxx-E-AC; SPR-X21-xxx; SPR-X21-xxx-BLK; SPR-X21-xxx-BLK-C-AC; SPR-X21-xxx-BLK-D-AC; SPR-X21-xxx-BLK-E-AC; SPR-X21-xxx-C-AC; SPR-X21-xxx-D-AC; SPR-X22-xxx; SPR-X22-xxx-C-AC; SPR-X22-xxx-COM; SPR-X22-xxx-D-AC; SPR-X22-xxx-D-AC; SPR-X22-xxx-E-AC; SPR-xxxE-WHT-D; SPR-xxxNE-WHT-D; SPR-Mxxx-H-AC; SPR-Mxxx-BLK-H-AC
Talesun	TP6L60M; TP6L60M(H); TP7F60M; TP7F60M(H); TP7F54M; TP7F54M; TM7G54M-xxx; TM7G54M(BK)-xxx; TP7G54M-xxx; TM3G48M-xxx
Tesla	SC31582; SCxxx; SCxxxB1; SCxxxB2; TxxxS; TxxxH; SxxxH
Trina	TSM-xxxDD05A; TSM-xxxDD05A(II); TSM-xxxDD05A.05(II); TSM-xxxDD05A.08(II); TSM-xxxDD05A.18(II); TSM-xxxDD05H.05(II); TSM-xxxDD05H.08(II); TSM-xxxPA05.18; TSM-xxxPD05.05; TSM-xxxPD05.18; TSM-xxxPD14; TSM-xxxDD06M.05(II); TSM-DD06H.08(II); TSM-DD06H.05(II); TSM-DE09C.05; TSM-DE09.05; TSM-DE09.07; TSM-DE09C.07; TSM-DE06X05(II); TSM-DD06M.05(II); TSM-DE15V(II); TSM-DE15M(II); TSM-DE15H(II); TSM-14H(II); TSM-DE09.08; TSM-NE09RC.05; TSM-NE09RH.05; TSM-NED19RC.20; TSM-NEG19RC.20; TSM-NE19RC
United Ren. Energy	D6MxxxH3A
URE Co.	FAMxxxES-BB; FAMxxxE8G-BB; FBMxxxMFG-BB; FAKxxxC8G; FAKxxxE8G; FAMxxxE7G-BB; FBMxxxMFG; FBMxxxM7G-BB
Vikram	VSMDH.66.xxx.05; VSMDH.72.xxx.05; VSMDH.78.xxx.05; VSMDH.72.xxx.05
VSun	VSUN-xxx-108BMH; VSUNxxx-120BMH; VSUNxxx-108M-BB; VSUNxxx-144BMH-DG; VSUNxxxN-108BMH; VSUNxxxN-108MH
Waaree	WSMDi-xxx
Winaico	WSP-xxxM6
Yingli	YLxxxD-30b; YLxxxP-29b
ZNShine	ZXM6-NHLD144; ZXM8-SP150; ZXM8-SP120; ZXM8-SPLDD120; ZXM6-NH144; ZXM6-NH132; ZXM6-NH120; ZXM7-SPLD144; ZXM6-NHLD120; ZXM6-NHLD132; ZXM7-SH108



Appendix B - SkipRail Compatible PV Modules

The following PV modules are structurally compatible with the SkipRail installation method.

Manufacturer	Model
Alexus Solar	ALEX-530~550-W-72-S; ALEX-390~410-B-54-S
Aptos	DNA-144-BF26-xxxW; DNA-144-MF26-xxxW; DNA-120-BF26-xxxW; DNA-120-MF26-xxxW; DNA-120-MF10-xxx.W; DNA-120-BF10-xxx.W; DNA-108-BF10-xxx.W; DNA-108-MF10-xxxW
Axitec	AC-XXXMBT/108V, AC-XXXMBT/108US
Canadian Solar	CS6.1-54TM-xxxH; CS6.1-60TM-xxxH
Hyperion	DH108P8B-xxx
Hyundai	HiD-SxxxRG(BK); HiS-MxxxRG; HiS-SxxxKI; HiS-SxxxRG; HiS-SxxxRG(BK); HiS-SxxxRI; HiS-SxxxTI; HiA-SxxxHI; HiS-SxxxYH(BK); HiS-SxxxXG(BK); HiN-SxxxXG(BK); HiN-TxxxNF(BK)
JA Solar	JAM54S30-xxx/LR; JAM54S30-xxx/MR; JAM54S31-xxx/MR; JAM54D40-xxx/MB; JAM54D41-xxx/MB
Jinko	JKMxxxM-72HL-V; JKMxxxM-72HBL-V; JKMxxxM-6RL3-V; JKMxxxM-6RL3-B; JKMxxxN-54HL4-B
Longi	LR6-60BP-xxx; LR6-60HPB-xxx; LR6-60HPH-xxx; LR6-60PB-xxx; LR6-60PE-xxx; LR6-60-xxx; LR4-60HPH-xxxM; LR4-60HPB-xxxM; LR4-72HPH-xxxM; LR4-72HBD-xxxM; LR5-54HPH-xxxM; LR5-54HPB-xxxM; LR5-54HABB-xxxM; LR5-54HABD-xxxM; LR5-66HPH-xxxM
Maxeon	SPR-MAX3-xxx-R
Meyer Burger	MB_W120AyB-xxx; MB_120AyB-xxx
Mission Solar	MSExxxSX6Z; MSExxxSX5T; MSExxxSX5K; MSExxxSX6Z; MSExxxSX6S; MSExxxSX9R; MSExxxSX9Z; MSExxxHT0B; MSX10-xxxHN0B
mSolar	TXI10-xxx108BB
Philadelphia Solar	PS-MNB108(HCBF)-xxxW
Phono Solar	PSxxxM6H-18/VHB; PSxxxM8GFH-18/VNHB; PSxxxM8GFH-18/VNH; PSxxxL8GFH-16/QNH
QCells	Q.PEAK DUO BLK-G10 xxx; Q.PEAK DUO BLK-G10+ xxx; Q.PEAK DUO ML-G10+; Q.PEAK DUO BLK ML-G10.a+; Q.PEAK DUO XL 10.d/BFG; Q.PEAK DUO-G10 xxx; Q.PEAK DUO-G10+ xxx; Q.PEAK DUO-G10.a xxx; Q.PEAK DUO-G10.a+ xxx; Q.PEAK DUO BLK-G10.a xxx; Q.PEAK DUO BLK-G10.a+ xxx; Q.PEAK DUO ML-G10 xxx; Q.PEAK DUO ML-G10.a xxx; Q.PEAK DUO ML-G10.a+ xxx; Q.PEAK DUO BLK ML-G10 xxx; Q.PEAK DUO BLK ML-G10+ xxx; Q.PEAK DUO BLK ML-G10.a xxx; Q.PEAK DUO ML-G10+ t xxx; Q.TRON BLK M-G2+ (/AC) xxx; Q.PEAK DUO (BLK) M-G11S+ xxx;
REC	RECxxxNP; RECxxxNP Black; RECxxxPE; RECxxxPE 72; RECxxxPE(BLK); RECxxxTP; RECxxxTP BLK; RECxxxTP2; RECxxxTP2 BLK; RECxxxTP2 BLK Q2; RECxxxTP2 BLK2; RECxxxTP2M; RECxxxTP2S 72; RECxxxAA; RECxxxAA Black; RECxxxAA 72; RECxxxNP3; RECxxxNP3 Black; RECxxxNP2; RECxxxNP2 Black; RECxxxAA Pure; RECxxxAA Pure-R; RECxxxAA Pure 2
SEG Solar	SEG-xxx-BTB-BG; SEG-xxx-BTD-BG; SEG-xxx-BMB-HV; SEG-xxx-BMD-HV; SEG-xxx-BMB-BG; SEG-xxx-BMD-BG; SEG-xxx-BMB-TB; SEG-xxx-BMD-TB
Silfab	SIL-xxxHC; SIL-xxxHC+
Solar4America	S4A410-72MH5BB; S4A33-60MH5BB; S4Axxx-108MH10BB; S4Axxx-144MH10STT
Sonali	SS-XXXW-M60 M10
URE Co.	FBMxxxMFG; FBMxxxMFG-BB
Vsun	VSUNxxxN-108BMH; VSUNxxxN-108BMH-BW; VSUNxxxN-108BMH-BB; VSUNxxxN-108BMH-BT; VSUNxxxN-108BMH-WT; VSUNxxxN-108MH; VSUNxxxN-108MH-BW; VSUNxxxN-108MH-BB; VSUNxxxN-108MH-BT; VSUNxxxN-108MH-WT; VSUNxxxN-108M; VSUNxxxN-108M-BW; VSUNxxxN-108M-BB; VSUNxxxN-108M-BT; VSUNxxxN-108M-WT
Waaree	WSMDi-xxx
ZN Shine	ZXM7-UHLDD144-xxx/N; ZXM7-SHLDD144-xxx/M; ZXM6-NHLDD144xxx/M



Appendix C

Warranty and External Links

PE Certifications and Span Tables

www.pegasussolar.com/spans

Warranty

www.pegasussolar.com/warranty

Comp Conduit Mounts and other Accessories

www.pegasussolar.com/accessories

